

USE AND CARE

CS-2

LABELING DEVICE

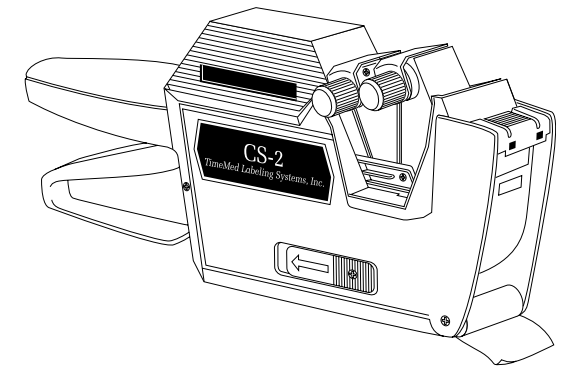

TimeMed Labeling Systems, Inc.

144 Tower Drive
Burr Ridge, IL 60527
800-323-4840
630-986-1800

9566 Vassar Ave.
Chatsworth, CA 91311
800-382-3371
818-882-8463

2808 McGowan Street
Dallas, TX 75203
800-833-2533
214-943-4688



1. To load label gun

Remove 7 to 10 labels from leading edge. Press both side locks and open cassette. Insert labels as shown in **Fig. A**. Thread labels under front edge label guides (**Fig. B**) and close cassette until it snaps. Feed Label between feed drive wheel and roller. Squeeze handle 6 or 7 times. The labels will feed through the gun. Select desired bands. The gun is now ready to use.

Fig. A

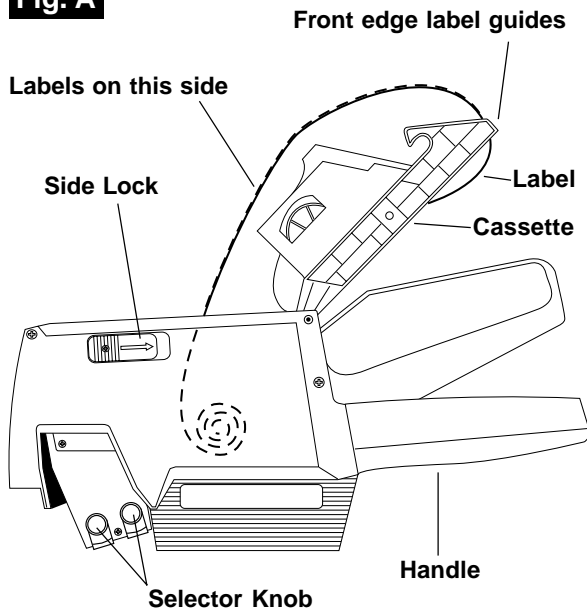
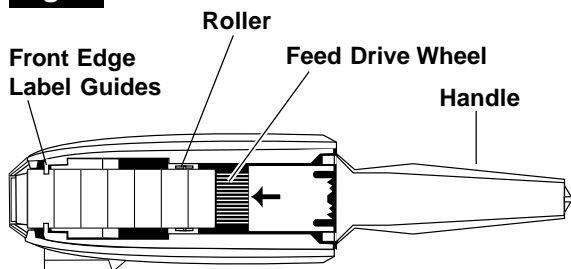

Fig. B



2. Setting the print bands

Pull selector knob (**Fig. C, No. 3**) out to desired position shown by selector indicator (**Fig. C, No. 4**) and turn knob. The white number (**Fig. C, No. 2**) appearing in the window will be the same as the number printing. Always be sure that the white portion of the band is displayed in the window.



IMPORTANT:

Band selector indicator must be positioned as shown in **Fig. C** before operating gun.

Fig. C

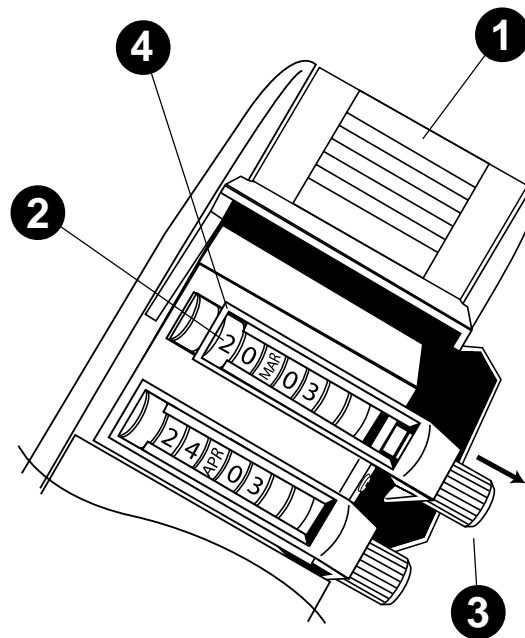

4. To remove ink roller carriage

Squeeze handle, exposing ridged areas (**Fig. D, No. 4**) of carriage, with thumb and index finger, pull carriage outward. To remove ink roller (**Fig. D, No. 2**) spread carriage legs apart (**Fig D, No. 3**). Roller will drop out.

5. To replace ink roller carriage

With thumb and index finger, insert carriage lip (**Fig. D, No. 1**) into small rectangular opening at top/front of gun at a 30-45° angle. When lip is fully inserted into opening, simply push carriage in and downward.

Fig. D

